

Mercedes-AMG C 43.



AMG
DRIVING PERFORMANCE



Fast driving. Quick shifting.



*Please read the disclaimer.

Consistently sporty appearance.





Sporty. Elegant. Aesthetic.

*Please read the disclaimer.

DYNAMIC SELECT – Individualised driving style at your fingertips

Motoring pleasure and sportiness are in the very nature of a roadster. With DYNAMIC SELECT, the Mercedes-AMG C 43 lives up to this promise in a highly targeted manner without neglecting comfort and consumption. At a touch of the DYNAMIC SELECT feature in the centre console, drivers can choose between comfortable, sporty, particularly sporty and efficient driving styles, or their own individually defined style. To achieve this, parameters such as the engine, transmission, suspension and steering characteristics are adjusted according to the selected drive mode. The standard setting is the well-balanced and fuel-efficient “Comfort” mode. The “Sport” drive mode offers further agility and dynamism thanks to its more progressive characteristic steering curve, sporty, taut suspension tuning, spontaneous throttle response and modified shift points (with automatic

transmission). The element of sportiness can be enhanced even further by switching to the “Sport+” mode. In this case the suspension and drive system are even more dynamically tuned. The ECO start/stop function is deactivated. The “Eco” drive mode is designed to keep fuel consumption as low as possible. This includes adjustments to the accelerator pedal curve and shift points. In addition, the output of equipment items such as heated seats, the heated rear window and the air conditioning is similarly adjusted. As soon as the driver takes the foot off the accelerator, the vehicle switches to using its own kinetic energy, so allowing it to coast in a very fuel-efficient manner. The “Individual” mode gives the driver the ability to adjust the various parameters such as the steering, drive system and suspension to suit his own requirements.



The sound for the track. The sports exhaust system

A noise becomes a feeling. Listening becomes experiencing. The new sports exhaust system alone is reason enough to open the roof of the Mercedes-AMG C 43. It produces a highly emotive and appealing sound. This is made possible by the modified structure of the exhaust silencer system: via the integral exhaust gas flap the sound characteristics adapt to the chosen DYNAMIC SELECT drive program. Every driving experience is thus given an optimum acoustic backdrop: powerfully increasing and rich when accelerating in the Sport Plus drive program, comfortably restrained during relaxed motoring. The emotive hallmark AMG sound of the sports exhaust system is particularly powerful when accelerating.

Overview of the sports exhaust system:

More advanced exhaust system with emotive engine sound. With lower counterpressure and reduced weight. Two tailpipe trim elements in twin-tailpipe design. In Sport mode: sporty characteristics, In Sport+ mode: exceptionally sporty and emotive 6-cylinder sound due to double-declutching function when shifting down and misfire, i.e. backfire applied deliberately when changing up.

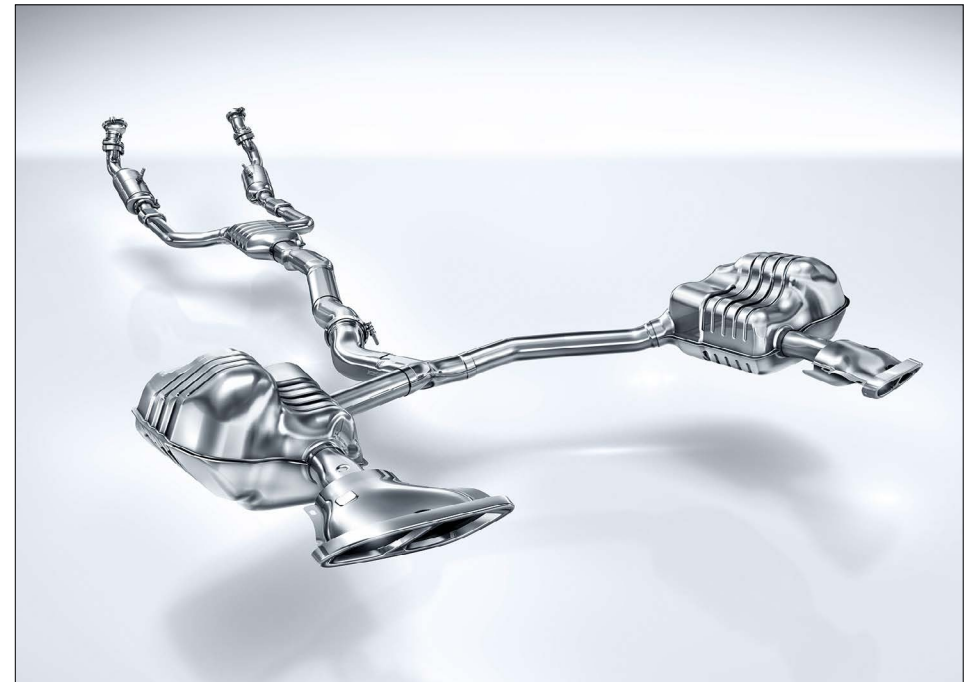

Engine and Transmission

Forceful, unmistakable. Sonorous 270 kW (367 hp) and a torque of 520 Nm catapult it in 4.7 seconds from 0 to 100 km/h.

V6 Petrol

Over 20% less fuel consumption and lower CO₂ emissions yet enhanced dynamism – a neat way of summing up the Mercedes-AMG C 43. A maximum output of 270 kW (367 hp) and peak torque of 520 Nm results in a power-packed performance while reducing fuel consumption with newly developed engine technologies. This is a hallmark of AMG Driving Performance. The new 6-cylinder unit takes a vigorous approach coupled with outstanding refinement across the entire engine speed range, even low down. The backdrop to this comes courtesy of an impressive soundscape – of the calibre that only a six-cylinder can muster.

9G-TRONIC Automatic Transmission

With nine forward gears, this automatic transmission combines efficiency, comfort and dynamics at an entirely new level. Even faster gear changes and smoother gear shifting make it an enticing proposition. At the same time, 9G-TRONIC helps to reduce fuel consumption.



Chassis and Suspension

From highly comfortable to sporty and firm: AMG RIDE CONTROL sports suspension with 3-level adaptive damping adjustment

With its sportily tuned suspension, the Mercedes-AMG C 43 is already optimally prepared for a dynamic driving style – whilst remaining astonishingly comfortable. With the AMG sports suspension or the Dynamic Handling package, fun at the wheel can be tangibly increased yet further through selectable suspension set-ups.

AMG RIDE CONTROL sports suspension

With its adjustable, electronically controlled damping system, this steel chassis provides both sporty vehicle dynamics as well as brand-typical comfort on long journeys. The basis for this comes courtesy of a 4-link front axle and a multi-link independent rear suspension. The AMG-specific kinematics and elastokinematics with newly developed components result in very high camber stability during dynamic cornering. The axial brake connection on the front axle supports agile, precise handling.

The damping tuning is controlled individually for each wheel and is dependent on the driving style, the road surface condition and the selected suspension level.



Virtuoso: the Mercedes-AMG C 43

Pressed into the artico / DINAMICA microfibre sports seats by the acceleration and the sports steering wheel with shift paddles firmly in hand, the AMG excitement sweeps you away. Everything points to sport on the exterior, too: 45.7 cm (18-inch) AMG light-alloy wheels, two chromed tailpipe trims with a centrepiece, black exterior mirrors – and the inimitable face of AMG.

In the Mercedes-AMG C 43, virtually your every wish is catered for as standard when you take a seat. The comprehensive safety equipment and numerous exclusive details such as the multifunction sports steering wheel in a 3-spoke design, firm sports seats, the air-conditioning and headlamps with their integral LED daytime running lamps give your roadster that very special something in its standard-specification guise. The Audio 20 CD ensures yet more music and the best connections. It features internet capability, a radio, twin-tuner and a CD drive which facilitates networking with mobile devices via Bluetooth®.

Exterior Highlights

- Dynamic LED Headlamps with integrated DRLs
- Sports exhaust system
- Electrically folding exterior mirrors in Black
- Diamond grille with Mercedes-Benz star in Chrome
- AMG body-styling
- AMG spoiler lip in vehicle colour
- Windscreen wipers with rain sensor
- 45.7 cm (18-inch) AMG 5-spoke light-alloy wheels
- AMG Line exterior
- AMG RIDE CONTROL sports suspension
- MIRROR PACKAGE
- Ambient Lighting with Logo projection

Interior Highlights

- | | |
|--|---|
| Sports steering wheel | DYNAMIC SELECT with 5 drive modes |
| AMG Line interior | Illuminated Door sill panels with 'AMG' lettering |
| Black upholstery in ARTICO / DINAMICA microfibre | Analogue clock in centre console |
| Red seat belts | Panoramic sliding sunroof |
| Black open pore ash wood trim | Parking Package including Active Parking Assist |
| Ambient lighting | Garmin® MAP PILOT |
| MB Apps | |



Standard Equipment

AMG speed-sensitive sports steering 2-stage

With a variable steering ratio, the AMG speed-sensitive sports steering supports a dynamic style of driving. The 2-stage speed-sensitive steering ensures adjustment of the steering characteristics depending on the setting for a comfortable or sporty steering sensation.

AMG sports braking system

High grip, sporty and high quality: brake callipers with “AMG” lettering come with the Mercedes-AMG C 43. The sports braking system features internally ventilated compound brake discs on the front and rear axle. The silver-painted brake callipers with black “AMG” lettering on the front axle lend the braking system a high-quality, sporty character. The sports braking system with 4-piston fixed callipers provides excellent deceleration values and precise brake control thanks to its internally ventilated brake discs all round.

LED Intelligent Light System

For the best possible visibility on country roads and motorways, when cornering and on bends, the LED Intelligent Light System automatically adapts to the lighting and driving conditions. The tail lights also feature LED technology and with their horizontal 2-torch design create a visual highlight at the rear while improving visibility. When unlocking the vehicle the welcome light greets the driver with an exceptional light display. LED technology results in very low energy consumption and a long service life. In addition to the striking look, LED technology features greater luminosity while producing less glare.



Standard Equipment

Windscreen wipers with rain sensor

The electronically controlled rain sensor automatically detects water on the windscreen and activates the intermittent wipe accordingly when the driver switches the system on. The sensor is located behind the rear-view mirror on the inside of the windscreen and transmits an infrared beam onto the screen at a certain angle. The beam is reflected back differently according to the amount of water on the windscreen. The amount of light reflected is used by an electronic system to control the wiper cycle from a single wipe to continuous wiping. To avoid icing or condensation, the area monitored by the sensor is heated.



AMG bodystyling – exclusive sportiness

The powerful AMG bodystyling ensures a dynamic, dominant appearance from any angle. It comprises the specific front apron with front splitter in the vehicle colour, A-wing painted in high-gloss black with trim strip in silver chrome and also black flics. In the case of the AMG rear apron, diffuser fins and a trim strip in silver chrome create distinct, sporty highlights. The side sill panels and wheel arch claddings in the vehicle colour and AMG brake callipers round off the exterior.



Parking package – parking made simple

Active Parking Assist makes it easier to find a parking space and also to enter or leave longitudinal parking spaces. The system automatically steers the vehicle into parking spaces, relieving the driver of the work of steering and braking. The reversing camera makes reverse parking and manoeuvring much easier and safer. It is switched on automatically when the driver selects reverse gear, and shows the driver the area behind the vehicle with dynamic guide lines on the Media Display. If the driver does not wish to use Active Parking Assist, the PARKTRONIC electronic parking assistance system monitors the front and rear areas while the driver is manoeuvring the vehicle and warns the driver if a risk of collision is detected.

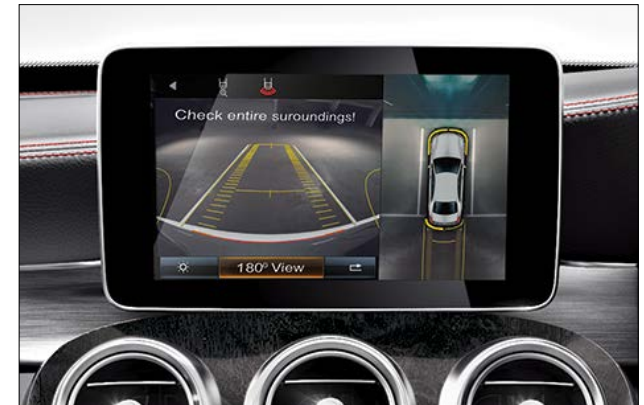

Upholstery, Trim, Paintwork and Alloy

UPHOLSTERY

ARTICO man-made leather / DINAMICA microfibre - black



TRIM

Black open-pore ash wood trim



METALLIC PAINTS

Obsidian Black

Brilliant Blue



NON-METALLIC PAINT

Polar White



designo PAINT

designo Hyacinth Red



ALLOY

45.7 cm (18-inch) AMG 5-spoke light-alloy wheels



Dimensions

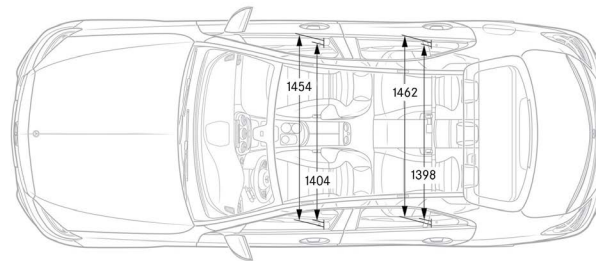
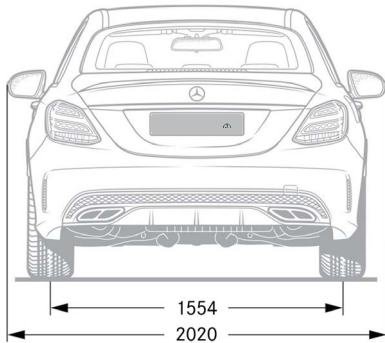
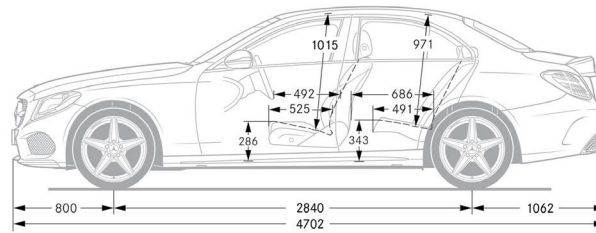
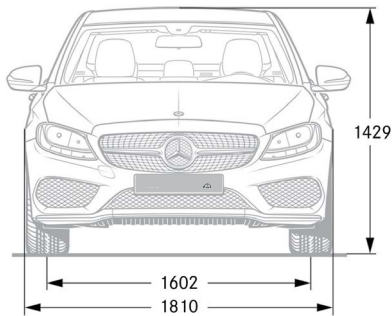

Technical data

	Mercedes-AMG C 43
No. of cylinders/arrangement	V6
Total displacement in cc	2996
Rated output in kW (hp) at rpm	270 (367) @ 5500-6000
Rated torque in Nm at rpm	520 @ 2000-4200
Transmission	9G-TRONIC
Acceleration from 0 to 100 km/h in s	4.7
Top speed, approx. in km/h	250
Tank capacity, of which reserve, approx. in l	66/7
Turning circle diameter in m	11.70
Kerb weight in kg	1690
Perm. GVW in kg	2225
Wheelbase in mm	2840
Length x Width x Height (mm)	4702 x 1810 x 1434

All dimensions in millimetres. The dimensions shown are mean values and apply to standard-specification, unladen vehicles.

Service

The luxurious experience of driving a Mercedes-Benz is converted into a fulfilling ownership experience with a range of exclusive services and special programmes.

Cost of Ownership

There has been a paradigm shift in the buying preferences of Indian consumers over the years, even for the luxury products. The purchase decision not only dwells around cost of acquisition but also the total 'Cost of Ownership' (COO). Amongst the key components of COO in cars are the routine service jobs and the unplanned repair expenses post the warranty period. We are now offering highly-affordable Service Packages and Extended Warranty Programmes which are the most competitive packages in its class. All in all, we provide you with a controlled Cost of Ownership while you benefit from the legendary Mercedes-Benz service quality.

Experience complete peace of mind when you drive the Star

STAR CARE programme offers peace of mind drive for you during warranty period and beyond. While our cars are covered for warrantable repairs up to 3 years without any mileage limitations, as standard, you can also buy STAR CARE Plus programme, offering 4th year extended warranty. Additionally, the programme enhances the resale value of your car.

STAR EASE Service Package gives you the freedom to relax behind the wheel and puts your mind at ease with its range of unique benefits such as defined cost of maintenance and priority handling. STAR EASE Comprehensive package covers essential jobs related to periodic service (viz. oil, filters, consumables, etc.) along with coverage for brake pads, brake discs, wiper blades and wheel alignment & balancing, for a contracted period. For further details on products and pricing, please contact your nearest Mercedes-Benz dealer.

On-Road Assistance Programme

As part of our ongoing commitment to you, Mercedes-Benz On-Road Assistance is designed to enhance your overall Mercedes-Benz ownership experience by providing you with 24-hour On-Road Assistance. Mercedes-Benz is the only Luxury car manufacturer to offer round-the-clock On-Road Assistance for 3 years from purchase of vehicle as a standard offering. Peace of mind motoring – guaranteed.



Extended Warranty that guarantees complete peace of mind



The maintenance of your Star is just as peaceful as driving it



Always at your service

India's Largest Luxury Car Network

It takes a keen sense of responsibility to provide the Best. Our large network is spread across the country in 40 cities with 86 outlets and is still growing. With world-class showrooms, state-of-the-art workshops and highly skilled personnel, experience the best wherever you go.

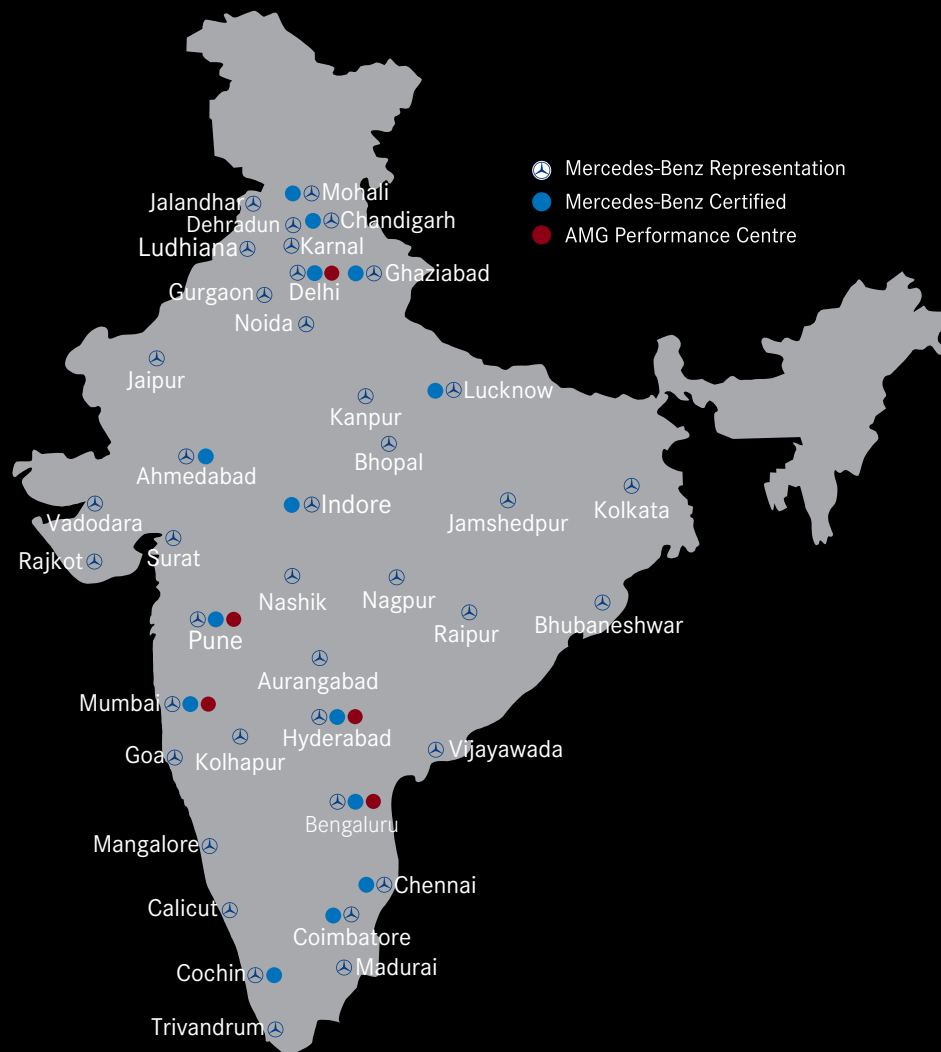

DEALER CONTACT:

NORTH & EAST:

BHUBANESWAR:

Tristar Motors: 0-7852944100

CHANDIGARH:

Joshi Autozone: 0172-5050500

Panjab Motors: 0172-4290000

DEHRADUN:

Berkeley Motors: 0135-3054000

DELHI:

T & T Motors, Mohan Co-operative,
Mathura Road: 011-66574300/330

Rajouri Garden: 011-66574400/430

GHAZIABAD:

Silver Arrows: 0-9718200500

GURGAON:

T & T Motors: 0124-4263060/62

JAIPUR:

T & T Motors: 0141-4300000/05

JAMSHEDPUR:

Tristar Motors: 0-7763815720/
0657-6601601/02

JALANDHAR:

Joshi Autozone: 0181-5004444

KANPUR:

Smart Hoops: 0-8795663300

KARNAL:

Berkeley Motors: 0184-3300000

KOLKATA:

Benchmark Interkrafts: 1800 3000 3310

LUCKNOW:

Smart Hoops: 0522-6004008/9

LUDHIANA:

Joshi Autozone: 0161-5055000

MOHALI:

Panjab Motors: 0172-4290000

NOIDA:

Silver Arrows: 0-9999200500

WEST:

AHMEDABAD:

Benchmark Cars: 0-9377662000

Emerald Motors: 0792-6446694/95

AURANGABAD:

B. U. Bhandari: 0-8605121333/
0240-6452601/02

BHOPAL:

Benchmark Cars: 0-9098233233

GOA:

Counto Motors: 0832-2415122

INDORE:

Benchmark Cars: 1800-3000-8844

KOLHAPUR:

B. U. Bhandari: 0231-2661422/
0-8380093555

MUMBAI:

Auto Hangar, Prabhadevi: 022-67434362/63

Auto Hangar, Andheri: 022-67106660/61
Metro Motors, Auto Hangar division
Hughes Road: 022-66123500/11
Shaman Wheels, Off BKC: 022-24228787

NAVI MUMBAI:
Shaman Wheels: 022-24228787

NAGPUR:
Auto Hangar: 0-9223540191 /
07104-238180/1/2/3

NASHIK:
Indisch Motoren: 0253-6645555

PUNE:
B. U. Bhandari, Baner: 020-67212129
B. U. Bhandari, Bund Garden: 020-67212131
Trinity Motors: 020-67342525

RAJKOT:
Benchmark Cars: 0-9377750050

RAIPUR:
Auto Hangar: 0771-6537801/0-8518887155

SURAT:
Benchmark Cars: 0-9377660066

VADODARA:
Benchmark Cars: 0-9377390001

SOUTH:

BENGALURU:
Sundaram Motors: 080-22070720/21

Akshaya Motors, Mysore Road:
080-22966300, 0-9066030989

Akshaya Motors, Koramangala:

080-22966296, 0-9019326026

CALICUT:
Bridgeway Motors: 0495-30 55555

CHENNAI:
Trans Car: 044-40200300
Titanium Motors: 044-66498080/8181/8282

COIMBATORE:
Sundaram Motors: 0422-2452020

COCHIN:
Rajasree Motors:
0484-2706332/2706432/2706134
2607027/37/47

HYDERABAD:
Mahavir Motors: 040-43403004
Silver Star: 040-30003535/0-72888862888

MADURAI:
Sundaram Motors: 0452-2320433/
0-9500966946

MANGALORE:
Sundaram Motors: 0824-2214833/2215833/
0-9008442155

TRIVANDRUM:
Rajasree Motors: 0471-2380377/
0-9846547551

VIJAYAWADA:
Mahavir Motors: 0866-2082559/
0-9885303004

MERCEDES-BENZ CERTIFIED:

AHMEDABAD:
Benchmark Cars: 0-9016665000
Emerald Motors: 0792-6446694/95

BENGALURU:
Akshaya Motors: 0-9019944044
Sundaram Motors: 080-22070746/
0-9880662051

CHANDIGARH:
Joshi Autozone: 0-9878941930/
0172-5050500/510

CHENNAI:
Transcar: 0-9841049994

COIMBATORE:
Sundaram Motors: 0422-2452020

DELHI:
T&T Motors, Mathura Road: 0-9711774424
T&T Motors, West Delhi: 0-9711112243

GHAZIABAD:
Silver Arrows: 0-9718200500

HYDERABAD:
Adishwar: 0-7799633004

INDORE:
Benchmark Cars: 0731-6675520

KOCHI:
Rajasree Motors: 0-9846547311

LUCKNOW:
Smart Hoops: 0-8189004408/9/10

MOHALI:
Panjab Motors: 0172-4290000

MUMBAI:
Autohangar India: 0-9223546204,
0-9223547099
Shaman Wheels: 0-9619023450/
022-69543333

PUNE:
B U Bhandari: 020-67212172/0-8605118555

AMG PERFORMANCE CENTERS:

BENGALURU:
Sundaram Motors: 080-22070720/21

DELHI:
T&T Motors: 011-66574309

HYDERABAD:
Mahavir Motors: 0-9885033004/
0-9885653004

MUMBAI:
Auto Hangar: 022-67434360/61/65

PUNE:
B.U. Bhandari: 020-67212131/0-8554055555

Our national toll-free no.:

1800 102 9222

One Call. All Answers.

**For a complete list of
Mercedes-Benz outlets,
please explore the dealer locator
tab on www.mercedes-benz.co.in**

Mercedes-Benz India Private Limited: E-3, MIDC Chakan - Phase III, Chakan Industrial Area, Kuruli & Nighoje, Tal: Khed, Pune - 410 501 (India)
Toll free No.: 1800 102 9222. e-mail: customerconnect@daimler.com, **website: www.mercedes-benz.co.in**

Please note: This brochure is intended for general information, description and illustration of the Product including optional functions and equipment and may not be specific to a Product since specification of a product may change from time to time. Optional features, functions and equipment etc. may not be present in the Standard or Variant Product or Special Edition Product. Further, Standard specifications of a product may also vary from time to time. Colours may differ from those shown in pictures in the brochure, owing to printing. Mercedes-Benz India reserves the right to make changes, at any point of time, without prior notice, in design, colours, materials, components, equipment, specifications, features, functions, make and models etc. The information given in this brochure shall be regarded as accurate at the time of going to print and may vary thereafter due to any developments or any other reason. Interested parties should confirm with the Authorised Dealer about the correct specification of the product they desire to purchase. For the latest authentic information and updates, kindly contact your nearest Authorised Dealer.

All title, ownership rights and intellectual property rights in and relating to this brochure / magazine or publication material or any copies thereof including but not limited to copyright, logos, names, trademarks, service marks, design, text, images, links, concepts and themes are owned by Daimler AG and/or its subsidiaries collectively or used under authorised license by the Daimler AG. Any reproduction, transmission, publication, performance, broadcast, alteration, license, creation of derivative works or other use in whole or in part in any manner without the prior written consent of the Daimler AG is strictly prohibited.

Month of going to press: November, 2016. The Mercedes-AMG C 43 meets Bharat Stage IV equivalent emission norms.

CIN - U34102PN1994PTC083160